

OITDA Standard

TP

Technical Paper

**Optical Fiber Distribution System for
Apartment Houses in FTTH**

Third Version

Published in August, 2011

Coordination Committee:
Fiber Optics Standardization Committee
Sub-committee on In-house optical fiber distribution system

OITDA

Published by:

Optoelectronic Industry and Technology Development Association (JAPAN)

FOREWORD

This is a technical paper (TP) on the standardization published by Optoelectronic Industry and Technology Development Association (OITDA). TP is published to announce the proposed standards, provide technical materials on standardization, or to supplement the standards.

Figure 1 indicates the number of broadband service subscribers by type of access network such as FTTH, DSL, and CATV. Figure 2 shows the net increase/decrease of subscribers of FTTH and DSL on a quarterly basis ⁽¹⁾. The number of broadband service subscribers has steadily increased, reaching 34,585 thousands at the end of 2010. In addition to the existing fixed-type services such as FTTH, DSL, CATV, and FWA, the number of broadband service subscribers using a mobile (wireless) communication system such as BWA (WiMAX) and the Long Term Evolution (LTE, 3.9-generation mobile phone packet telecommunication service) is also published. The number of FTTH subscribers has maintained its strong net increase of more than 650,000 per quarter and reached 19.77 million subscribers at the end of 2010. IT is expected that the number of subscribers will exceed 20 million by the end of March 2011.

We have the standard of optical fiber distribution system for premises, “TS C 0017 Optical Fiber Distribution System for Customer Premise”. Today, the optical fiber distribution is widely adopted in factories, hospitals, and apartment houses. Among them, apartment houses have a special feature that each dwelling unit in the premise is an optical service user. It also means that a special optical fiber distribution system is required.

The advantages of applying an optical fiber cable to apartment houses are as follows:

- (i) Long distance transmission (while the maximum transmission length is 90 m for a metal cable, it is indefinite for an optical fiber cable in an apartment house.)
- (ii) Ultra broadband transmission is possible (while the transmission speed is 1 G bit/s for a metal cable, it can be 100 G bit/s or more for an optical fiber cable.)
- (iii) Compact.
- (iv) Noiseless (The metal cable generates a noise, as the vertical backbone cable to upper floors has an antenna effect.)
- (v) A direct contract is allowed between each dwelling unit and a telecommunication service provider for the use of optical service.

This TP systematically describes the optical fiber distribution configuration and cabling method in apartment houses in FTTH and composing parts and materials for FTTH. This is the update of the second version published in June 2009 to reflect the latest technological and product trend. Compared with the situation at the time of publishing the second version, the use of FTTH (Fiber to The Home) service with an optical fiber cable has disseminated sharply in conjunction with the diversification of FTTH service, and more apartment houses have introduced the optical fiber cable service. As a result, the price of transmission equipment gets cheaper, and various optical fiber cables, connection boxes, and tools are marketed that lead to easier introduction of optical fiber cables.

This TP is prepared as part of the information dissemination/provision activities to provide the latest optical fiber distribution technical information on FTTH. We expect that this TP is used as a guideline for the residents, developers, designers, and constructors who intend to introduce the optical fiber distribution system in apartment houses as well as further accelerate the promotion and dissemination of FTTH service user environment.

Please note that part of the TP may infringe the patent right, patent application after the announcement of application, utility model right, or utility model application after the announcement of application that have a technical nature. OITDA is not liable for confirming that the TP does not infringe such patent right, patent application after the announcement of application, utility model right, or utility model application after the announcement of application.

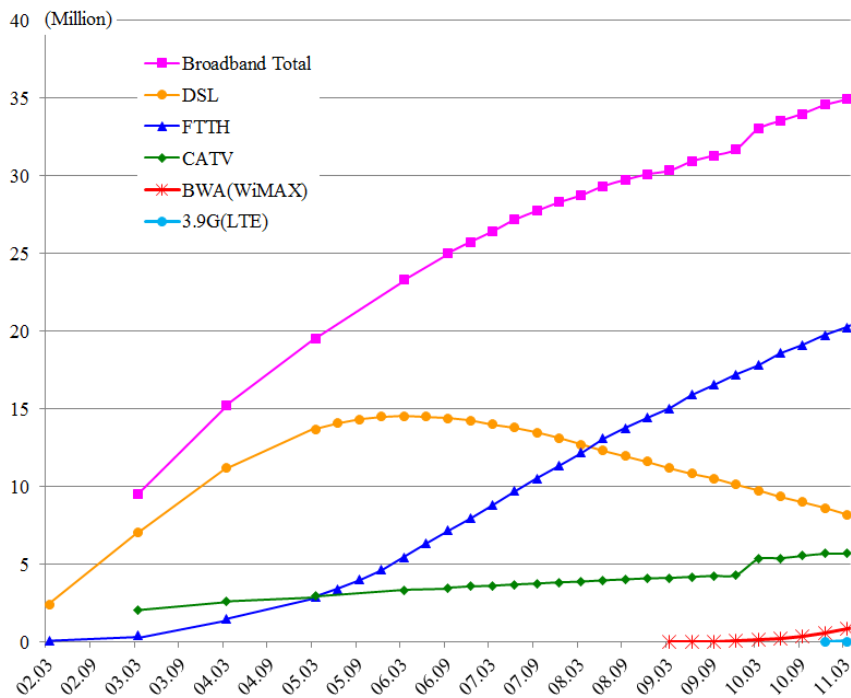

Figure 1: The number of broadband service subscribers

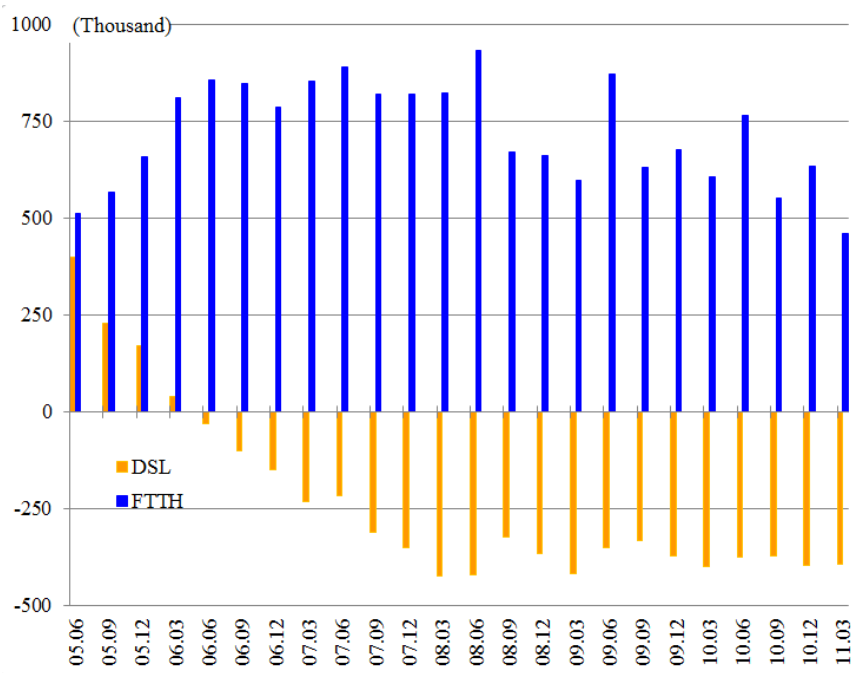

Figure 2: The net increase/decrease of subscribers of FTTH and DSL

Table of Contents

Introduction.....	5
1. Scope.....	5
2. Definitions and Abbreviations.....	5
2.1 Definitions.....	5
2.2 Abbreviations.....	6
3. Reference Standards.....	6
4. Basic Configuration of Optical fiber Distribution System.....	7
4.1 Summary.....	7
4.1.1 FTTH in apartment houses.....	7
4.1.2 Basic Configuration of Optical fiber Distribution System.....	8
4.2 Basic Components of Optical fiber Distribution System.....	10
4.2.1 Entrance facility.....	10
4.2.2 MDF Room.....	11
4.2.3 Backbone Cable Distribution.....	12
4.2.4 Horizontal Cable Distribution.....	15
4.2.5 Cabling Distribution for Small Apartment Houses without a Cabling Space within a Premise....	15
4.2.6 Termination at a dwelling unit.....	15
5. Cabling and Connection.....	17
6. Maintenance and Management.....	17
7. Test and Performance Standard.....	18
Reference.....	18
Annex A: Latest Examples of Services Using Optical Fiber Distribution System.....	19
Annex B: Result of Questionnaires about Optical Fiber Distribution System in Customer Premise.....	22
Description.....	30

*** Position of this TP**

- This TP is updated from time to time to meet the technical advancement in optical fiber distribution system for detached houses in FTTH
- Please send your opinions and information to the following contact:

Contact: Standardization Office, Optoelectronic Industry and Technology
Development Association (JAPAN)

e-mail : [hyojun @oitda.or.jp](mailto:hyojun@oitda.or.jp)

Optical Fiber Distribution System for Apartment Houses in FTTH

Introduction

This Technical Paper (TP) is a guideline based on the research and studies on optical fiber distribution system for apartment houses conducted since 2003. It aims at accelerating the introduction of optical fiber distribution system by establishing and improving a common understanding of system configuration, terminologies, and parts and materials in the construction of optical fiber distribution system in apartment houses.

1. Scope

The TP refers to the laying of silica glass single-mode optical fiber, installation of distribution board, optical fiber cable connection, test methods, display, and management regarding the optical fiber distribution system used in a single apartment house. We assume that major users of the TP are designers, constructors, and developers who intend to introduce FTTH service in apartment houses.

The scope of facilities are from the introduction of optical fiber cable to an apartment house, MDF facilities, backbone cable (vertical), horizontal cable (horizontal), to an optical wall outlet that is the introduction point at a dwelling unit such as a generic cabling box in a dwelling unit.

2. Definitions and Abbreviations

2.1 Definitions Definitions of terms used in this TP are as follows:

1) MDF Room

A room where a main distributing frame (MDF) is installed. The MDF has a function to connect a cable introduced from outside of the premise by a service provider with a cable distributing to each dwelling unit. As various equipment and cables that are used to distribute telecommunication, image distribution and security services to each dwelling unit are often installed in the MDF room, such area is also called as a connect area.

2) Backbone cable (vertical)

A cable installed vertically in an apartment house and connects a self PT board with a PD board. It can also be used to connect between PD boards in an apartment house.

3) Self PT board

A distribution board from at which the backbone cable starts. It has a patch panel with optical connectors and a facility demarcation point when connecting with an optical fiber cable from a telecommunication service provider. It is usually placed in a MDF room. It is also called as a user termination board or an optical termination box.

4) Combined Duct (CD duct)

One of the flexible synthetic resin cable conduit tubes that include Plastic Flexible (PF) conduit and Combined Duct (CD). While PF conduit has burning resistance (self-extinction), CD has no burning resistance (non self-extinction). CD is colored with orange for identification.

5) Centralized optical network unit

A network unit that is used when several dwelling units receive a unified service in an apartment house.

6) Generic cabling box

A distributor that centralizes the input and output of information from/to outside of the house (telephone, broadcasting, and telecommunications, etc.). It houses not only cables but also a terminal component of cables,

transmission equipment, and a splitter, and can be used for checking, maintenance, update, and mutual switching of information and telecommunication facilities.

7) Horizontal cable (horizontal)

A cable that connects the PD board and an in-house generic cabling box or an optical wall outlet. On the floor where the PD board is not installed, it is allowed to directly connect the optical wall outlet with a self PT board.

8) HUB

An integration equipment to mutually connect LAN equipment.

9) Optical outlet

A connector to terminate an optical fiber cable and provide an interface for the cabling of a terminal connection.

In this TP, it means equipment to terminate an optical fiber cable and connect an optical indoor cable with an optical fiber code that is connected with ONU. There are two types of optical wall outlet; the wall-embedded type (optical wall outlet) and the exposed type (optical outlet). In this TP, these are collectively referred to as an optical outlet.

10) Optical Network Unit (ONU)

Equipment that connects an optical fiber cable with a LAN cable such as UTP and mutually converts the optical signal to/from the electric signal in FTTH.

11) PT board (Termination board; optical termination box)

A distributor where a telecommunication service provider connects the optical fiber cable from the outside of the premise. It is usually placed in a MDF (telecommunication equipment) room.

12) PD board

A distributor that connects the backbone cable with a horizontal cable. It is usually placed in an EPS at a common space of residential premise. It is also called as a branching distributor or an optical connection box.

13) Media converter

Equipment to connect an optical fiber cable with a LAN cable such as UTP, and mutually converts the optical signal to/from the electric signal.

14) Router

Equipment that relays and switches the packets in accordance with the protocol definition on the network layer.

2.2 Abbreviations

The abbreviations used in this TP have the following definitions:

EPS	Electric Pipe Shaft
FTTH	Fiber To The Home
GL	Ground Level
LAN	Local Area Network
MDF	Main Distributing Frame
PD	Premise Distributor
PE	Polyethylene
PT	Premise Terminator
ONU	Optical Network Unit
V-ONU	Video-Optical Network Unit
UTP	Unshielded Twisted Pair cable

3. Reference Standards

The following standards constitute part of the provisions in this TP by referring to them in the TP. Among these

standards, only the version of the year that is clearly indicated constitutes the provisions of the TP, and their revised or supplemented versions do not apply.

JIS X 5150: 1996 Campus Generic Cabling System

JIS X 5150: 2004 Campus Generic Cabling System

JIS C 6841: 1999 Fusion Splicing Method of Optical Fiber

TS C 0017: Optical Fiber Distribution System for Customer Premise

4. Basic Configuration of Optical fiber distribution System

4.1 Summary

Existing apartment houses compatible with the optical service usually has a Main Distribution Frame (MDF) room in a common space into which the optical fiber is introduced by a telecommunication provider, and from which a metal LAN cable (UTP cable) is distributed to each dwelling unit (this part is regarded as a common facility of the apartment house).

However, as the number of users of FTTH has recently increased sharply, many large-scale apartment houses have adopted the so-called “Distribution method of optical fiber direct connection” which distributes an optical fiber to each dwelling unit as in the case of detached houses. For the purpose of this TP, an optical fiber cable means a cable using silica glass single-mode optical fibers.

Adopting the distribution method of optical fiber direct connection enables to ensure a high-speed and large-capacity telecommunications by each dwelling unit, and makes it easier to change a telecommunication provider after completing the construction. It also centralizes necessary works within a MDF room. As a result, each dwelling unit of an apartment house can enjoy high service performance that is equivalent to those for “detached houses in FTTH (Fiber to the Home) where optical fiber cables are used for in-house distribution. Therefore, we position the distribution method of optical fiber direct connection as the major “optical fiber distribution system for apartment houses in FTTH” and prepare this technical paper. In this chapter, we describe the current condition of FTTH in an apartment house, and a basic distribution configuration of the distribution method of optical fiber direct connection.

4.1.1 FTTH for Apartment Houses

Recently, the size and height of apartment houses increase that makes it difficult to distribute telecommunication messages with a metal cable in terms of the transmission distance and a distribution space within an EPS. Additionally, people living in an apartment house would like to have more free and flexible information infrastructure that enables them to freely choose any telecommunication provider by each dwelling unit or use an upgraded FTTH service in the future. In response to such needs, many apartment houses, mainly extremely high ones start adopting the “distribution method of optical fiber direct connection” that directly distributes an optical fiber to each dwelling unit which becomes a major trend of optical fiber distribution system for apartment houses. The type of services using the distribution method of optical fiber direct connection can be broadly divided into the dedicated-type service and the shared-type service.

Adopting the distribution method of optical fiber direct connection ensures a high-speed and large-capacity telecommunication service for each dwelling unit as well as to provide the FTTH service environment that can meet various needs of apartment house owners such as changing a telecommunication provider easily after completing the construction.

4.1.2 Basic Configuration of Optical Fiber Distribution System

1) Overall Configuration

Figure 1 shows a basic configuration of the optical fiber distribution system for apartment houses using the distribution method of optical fiber direct connection. The optical fiber distribution system consists of the introduction, MDF room, backbone cable, horizontal cable, each section (space) of each dwelling unit, and distribution equipment such as PT board, PD board, optical fiber cable, and optical wall outlet that are installed in each section (space) of each dwelling unit. Table 1 lists each distribution equipment (structural components) in each section (space) and the ownership category (an example).

In the FTTH optical fiber distribution using the distribution method of optical fiber direct connection, an optical fiber cable with several fibers is installed from the MDF room to each dwelling unit in accordance with the following rules:

- (1) One-to-one connection between the self PT board and an optical wall outlet of each dwelling unit;
 - (2) It is allowed to install a connection point (either permanent connection or connector connection, or both) between the self PT board and an optical wall outlet in a dwelling unit;
 - (3) In the case where branching, attenuation, or separation of wave length of optical signal is required, such functional element should be implemented in the upper cascade of the self PT board (in the primary side/telecommunication provider side), or the lower side of the optical wall outlet (in the secondary side) or after.
- It is not allowed to install any functional element other than the connection point between the self PT board and the optical wall outlet of each dwelling unit.

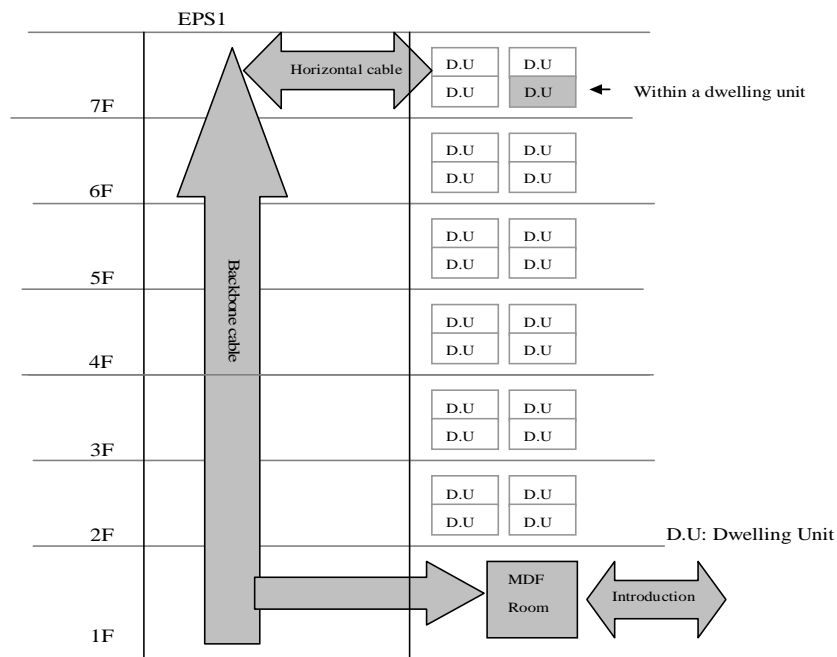

Figure 1: Basic Configuration of Optical Fiber distribution System for Apartment Houses in Distribution Method of Optical Fiber Direct Connection

Table 1 Example of Basic Configuration of optical fiber distribution system for apartment houses

Section (space)	Distribution equipment	Ownership category
Entrance facility	Optical fiber cable	Facility of telecommunication provider
MDF room	PT board	
	Self PT board	Common facility of apartment house
Backbone cable	Optical fiber cable	
Connection part of backbone cable and horizontal cable	PD board	
Horizontal cable	Optical fiber cable	
Within a dwelling unit	Optical wall outlet	

2) Selection of number of optical fibers per dwelling unit

The optical cable introduced to each dwelling unit usually use a horizontal cable with 1, 2, 4, or 8 fiber and connection units such as a optical wall outlet with each capacity is produced. Thus, it is appropriate to use such standardized products.

The number of optical fibers for apartment house should be comprehensively determined in consideration of the convenience and cost performance as well as the future trend. However, as shown in Table 2, two-fiber or four-fiber is currently adopted in many cases for the purpose of reserving the future use.

Based on such fact, the number of optical fibers should be adoption in accordance with either of the following principles:

(1) Introduction of optical cable with two fibers

One fiber is used for a telecommunication purpose and the other is used for other purposes;

(2) Introduction of optical cable with four fibers

In addition to the purposes of the above two fibers, one is for a facility specific to an apartment house (such as intercom, security and disaster prevention system, remote meter reading, and remote monitoring), and the remaining one is for new optical services introduced in the future.

Table 2 The number of fibers per dwelling unit and examples

The number of fibers	Optical fiber cable with two fibers		Optical fiber cable with four fibers		
	Example 1	Example 2	Example 1	Example 2	Example 3
1	For a FTTH contract of apartment house-type*	For a direct contract with a telecommunication provider	For a FTTH contract of apartment house type*	For a FTTH contract of apartment house-type**	For a direct contract with a telecommunication provider
2	Common antenna TV service	Reserved	Common antenna TV service	Common antenna TV service	Common antenna TV service
3	---	----	For transmission of signals for facilities	Reserve (For a direct contract with a telecommunication provider)	Antenna cabling for mobile telecommunication provider (in the case of extreme high-building)
4			Reserved (For a direct contract with a telecommunication provider)	Reserved	Reserved

*Shared-type service using an optical LAN method.

4. 2 Components for optical fiber distribution system

4.2.1 Entrance facility

An entrance facility means an area where a telecommunication provider introduces an optical fiber cable from outside to the MDF room of the apartment house. As the telecommunication provider lays the optical fiber cable, the apartment house owner needs to install a conduit tube for optical fiber cable in advance. The telecommunication provider either introduces the cable from an aerial cable or from an underground cable.

1) Introduction from underground cable

Although the details of introducing a cable from the underground cable should be consulted with the telecommunication provider, the following is generally recommended specifications:

- (1) Conduit: equivalent to PE 54
- (2) Number of conduit tubes: two to three conduit tubes for the purpose of adopting several telecommunication providers and a future use.
- (3) Underground laying depth: GL-900 mm (In the case sidewalk)
- (4) Protrusion of 300 mm from the boundary of the site

In addition to the above, the number of curve of underground conduit in the telecommunication introduction route and the interspaces of hand hole are same as those for an electric cable.

2) Introduction from aerial cable

A pole is installed within the site or a hook is placed at the point of introduction in the apartment building.

4.2.2 MDF room

Generally, the optical fiber cable is introduced to the telecommunication machine room (MDF room) where the telephone line is also introduced. Although it should be negotiated with a service provider, the major equipment installed is as follows:

- PT board (installed by the telecommunication provider)

A PT board is installed on a wood panel placed by the apartment house owner, or in a rack for PT board prepared by the telecommunication provider.

*A lot of PT board, equipment for premise LAN, and common antenna TV can be mounted on a 19-inch rack that conforms to the TIA/EIA-301-D Standards.

- Self PT board (installed by the apartment house owner)
- Such as electric power supply, earth connection, ventilation and others (generally installed by the apartment house owner)

1) Contract of distribution method of optical fiber direct connection (dedicated service)

The demarcation point is between the PT board and the self PT board. Both are connected with an optical code that is usually provided by the telecommunication provider to maintain the quality.

In the case where the distribution method of optical fiber direct connection is adopted, an optical fiber cable is distributed to each dwelling unit. Therefore, the cabling between the self PT board and each dwelling unit is either directly conducted by the telecommunication provider for the purpose of centralizing the responsibilities and management of the property, or the cabling after the self PT board is conducted by the apartment house owner. In either case, it should be determined at the discussion among the telecommunication provider and the owners of the apartment house or their agent such as a designer.

Generally, the PT board has a patch panel where the optical connector adopters are lined up. An optical fiber cable for an introduction cable and a backbone cable have an optical connector at the terminal and are connected to the optical connector adopter on the patch panel. The optical connection is generally the SC-type optical connector.

Figure 2 shows an example of patch panel in a self PT board.

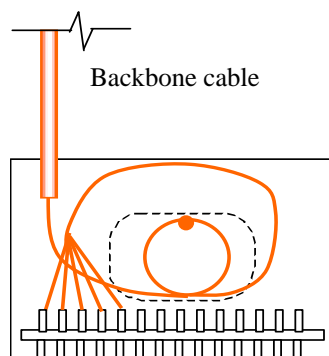

Figure 2 Example of Optical Patch Panel in Self PT Board (looking from the upper side)

2) Optical LAN method (shared service)

In the case the apartment house owners use a shared Internet service, the centralized cable termination equipment is installed in a MDF room. Although the installing place should be determined in consultation between the telecommunication provider and the apartment house owners, it is usually placed between the PT board of the telecommunication provider and the self PT board. Figure 3 shows an example where the telecommunication provider installs the centralized cable termination equipment in the Self PT board and connects the cable directly to each dwelling unit. There is a switching HUB (a proprietary asset of the service provider) in the secondary side

of the centralized cable termination equipment, and a patch panel where the optical connector adopters are line up is installed in the secondary side of the switching hub. Please be careful as there are also many other examples.

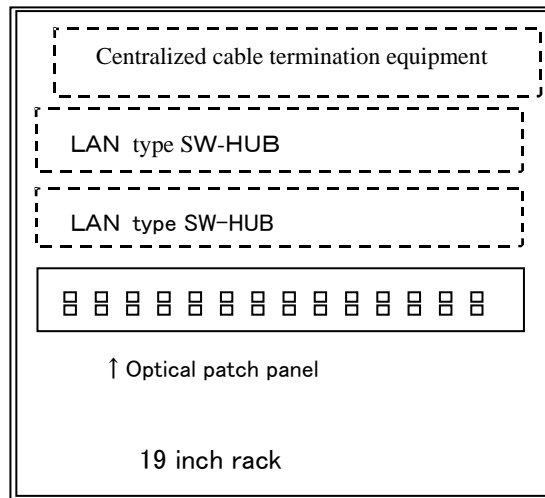

Figure 3: Example within a Self PT board (19-inch rack) (looking from the front side)

4.2.3 Cabling of backbone cable

For the backbone cable, as the required number of fibers are installed in each dwelling unit, the distribution method should be determined in consideration of the difficulty of installment, EPS space, and the cost. There are the following three methods for distribution method:.

The preconditions for the three methods are as follows:

- (1) Six stories (dwelling units exist from the second to the sixth floors)
- (2) Four dwelling units per floor; the total number of dwelling units is 20
- (3) The number of the optical fibers required per dwelling unit is two

Figure 4 shows a summary of three distribution methods.

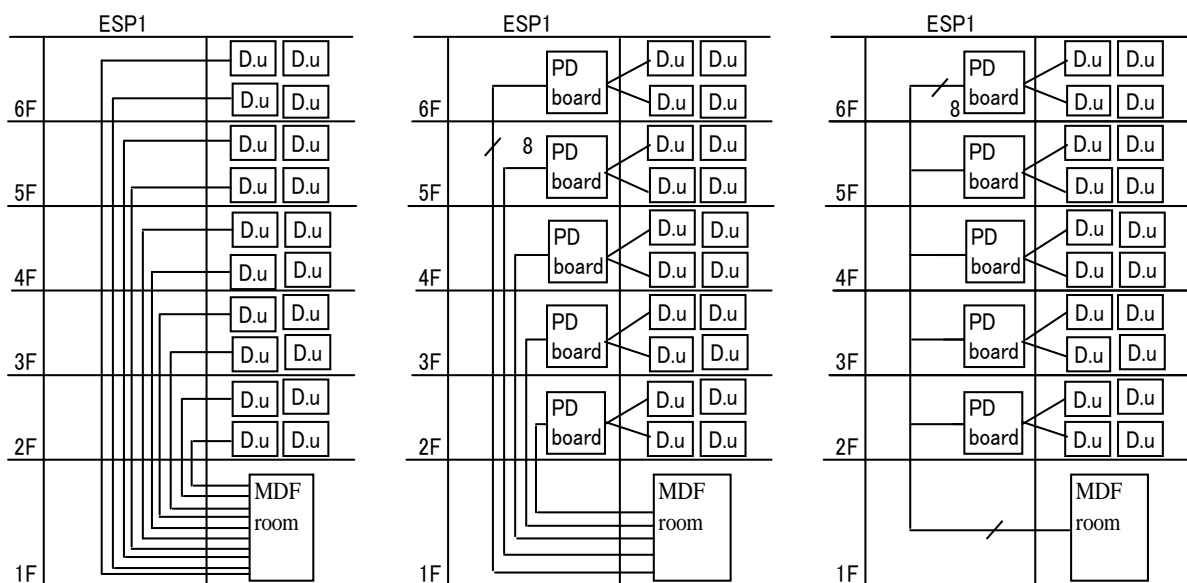

- 1) Horizontal cable single distribution method
Backbone cable: cable with two fibers x 20
- 2) Backbone cable single distribution method
Backbone cable; cable with eight fibers x 5
- 3) Backbone cable branching distribution method
Backbone cables; cable with forty fibers x 1

Figure 4 Distribution method of backbone cable

1) Horizontal cable single distribution method

(1) Summary

It is a method to directly distribute a horizontal cable with the small number of fibers and a small diameter that is used for the introduction to the dwelling unit from each dwelling unit to the self PT board installed in the MDF room. As this method has an easier configuration compared with other methods, its construction cost and period are smaller if it applies to a small- and medium-sized building. On the other hand, as the space required within the cable rack in the EPS is larger than those for other methods, it is not appropriate for a large-scale building and high building.

(2) Selection of optical fiber cable

The points to be checked at the time of laying the optical fiber cable are the permissible tension and permissible bending radius. Especially, a cable with the small number of fibers and a small diameter has smaller permissible tension. Therefore, we need to be careful to adopt this method, as the cable is laid from each dwelling unit to the MDF room. The permissible tension is approximately 150 N for a flat or parallel cable (or 35 N if the tension member is a steel cable and the non-inductive material such as fiber-reinforced plastics is used), or 500 N for round cable. As $1 \text{ kgf} = 9.80665 \text{ N}$, 150 N means an approximately 15 kgf of tension (for your reference, the permissible tension of UTP 0.5-4P cable is 110 N).

Particularly, in the case that a cable is introduced in a duct that has many curves, it may be difficult to wire the cable within the permissible tension. For the purpose of reducing the installing tension, a lubricant is applied to the cable before installing. However, if a cable with low friction is applied, the safety and the installation at the time of wiring and removing improve. Currently, as a cable of which external coat has low friction and of which outer diameter is small (hereinafter referred to as an “optical indoor cable of small diameter with low friction”) is marketed, we recommend applying such product. When we consider saving a space for a PD board and optical cabling, we recommend using an optical fiber cable of which permissible bend radius is 15 mm (30 mm for existing general products) that is generally available. For optical indoor cables of small diameter with low friction, a cable of which bend radius is 15 mm is also applied.

2) Backbone cable single distribution method

(1) Summary

It is a method to lay the backbone cable with multiple fibers in the vertical direction of the apartment house and connect to the horizontal cable with the PD board installed in the shaft (EPS). Its workability is good, as the backbone cable in the vertical direction and the horizontal cable in the horizontal direction can separately be constructed. However, it needs the PD board and the costs of materials and construction for connecting the optical fiber cable are expensive. If it is necessary to reduce the cost, one of the ideas is to install the PD board only in the even number floors to centralize the cables of two floors in a single PD board.

(2) Selection of optical fiber cable

The number of fibers of backbone cable with multiple fibers is 4, 8, 12, 24, or 48. The cable structure is the single-fiber layer twist type, or the slot type cable with single fiber, 2-fiber ribbon, 4-fiber ribbon, or 8-fiber ribbon.

(3) PD board

As the EPS of an apartment house is small, the facility space should be limited. Therefore, the PD board is usually installed on the wall. As the connection between the backbone cable and the horizontal cable is not expected to

change in the future, we recommend adopting a permanent connection method such as fusion splicing rather than the connector connection.

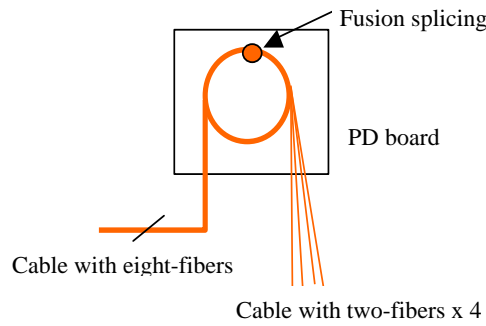

Figure 5: Example of PD board

3) Backbone cable branching distribution method

(1) Summary

It is a method to use a backbone cable with more fibers and install a branching point to the horizontal cable in each floor.

In the backbone cable branching distribution method, if the apartment house shown in Figure 4 has 30 stories, we need to have 29 backbone cables in the case the cable with eight-fibers is used in each floor. As the outer diameter of cable with eight-fibers (a single cable layer twist type or a single cable slot type) is approximately 12 mm, it requires a significant space. On the other hand, if the backbone cable branching distribution method is adopted, we only need three cables with 100-fibers (a slot type cable with fiber ribbon; the outer diameter is 15 mm). However, while the space required for the backbone cable is reduced, the cost for branching processing is added. Therefore, this method is appropriate for high buildings.

(2) Selection of optical fiber cable

It is generally a slot-type cable with single-fiber, two-fiber ribbon, four-fiber ribbon, or eight-fiber ribbon. However, if we plan to branch the cable in the mid span, we recommend using a SZ slot-type cable.

(3) Branching method

There are the following two branching methods:

(i) Local branching connection method

It connects the backbone cable with multiple-fibers with the horizontal cable in the PD board by processing it on site. Please see Figure 6.

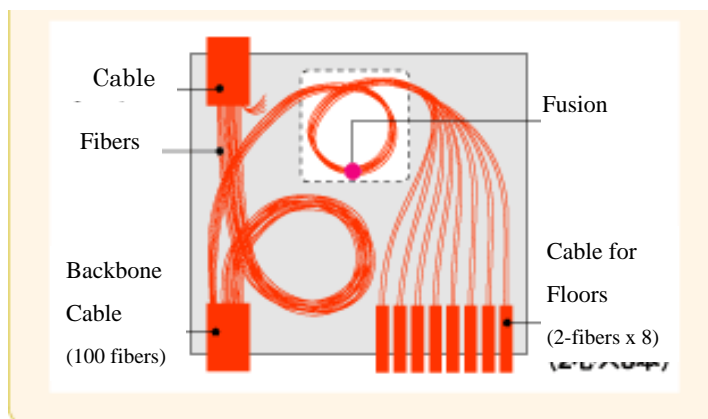

Figure 6 Branching of Backbone Cable in a PD board (source: Sumitomo Electric Works)

(ii) Backbone cable with branching cable

The backbone cable is processed in a plant to attach the branching cables that are long enough to reach the PD board and are connected with the horizontal cable in the PD board.

If the distance to each dwelling unit is short or the stories are not so high, the length of branching cable can be designed in advance and is directly introduced to each dwelling unit.

4.2.4 Distribution of horizontal cable

The cable with small number of optical fibers and a small diameter is laid from each dwelling unit to the PD board as a floor distribution (horizontal lines). As the horizontal distance is shorter than the cabling of backbone cable, it is recommended to use a flat or parallel cable (i.e. optical indoor cable) that is easy to be laid. Generally, as it is laid within a combined duct with a diameter of 22 mm or 16 mm, you need to check the permissible tension. We recommend using an optical indoor cable of small diameter with low friction if installing in the conduit that has many curves or if the cables are already installed in the conduit.

4.2.5 Cabling for Small Apartment Houses without a Cabling Space within a Premise

If there is no wiring space such as EPS and ducts in a small apartment house, IT is possible that a cable is installed on an external wall of the premise and introduced to each dwelling unit. In such case, we usually use a flat cable that has weather ability. However, due to effective wiring and consideration of beauty of the external wall, we recommend using an optical fiber cable which consists of 4 or 8 pieces of flat cables with weather ability for the external wall wiring purpose. Another method is to install a pipe with weather ability on an external wall of the premise and introduce a flat cable within the pipe. In this method, as many cables for each dwelling unit are introduced in one pipe, it is desirable to apply an optical indoor cable of small diameter with low friction in order not to damage the existing cables. If an applicable cable has no weather ability, it is necessary to protect the cable using another pipe or a cover from the branching point of the pipe to the introduction point of each dwelling unit.

4.2.6 Termination at a dwelling unit

A horizontal cable introduced to a dwelling unit is terminated in a generic cabling box or an optical wall outlet.

An optical connector is connected on-site at the end of the horizontal cable, or spliced by fusing or mechanically with the optical code with a connector. The optical connector is usually a SC type optical connector.

Figure 7 shows a basic configuration of in-house distribution. Because a PC and other information home appliances are installed in each room and in consideration of consistency with a TV receiver and redundancy for the future use, Figure 7 (a) shows an example of optical cabling configuration where a generic cabling box is installed and several terminals are used in a dwelling unit. For your information, Figure 7 (b) shows an example of optical cabling configuration where there is no space to install a generic cabling box.

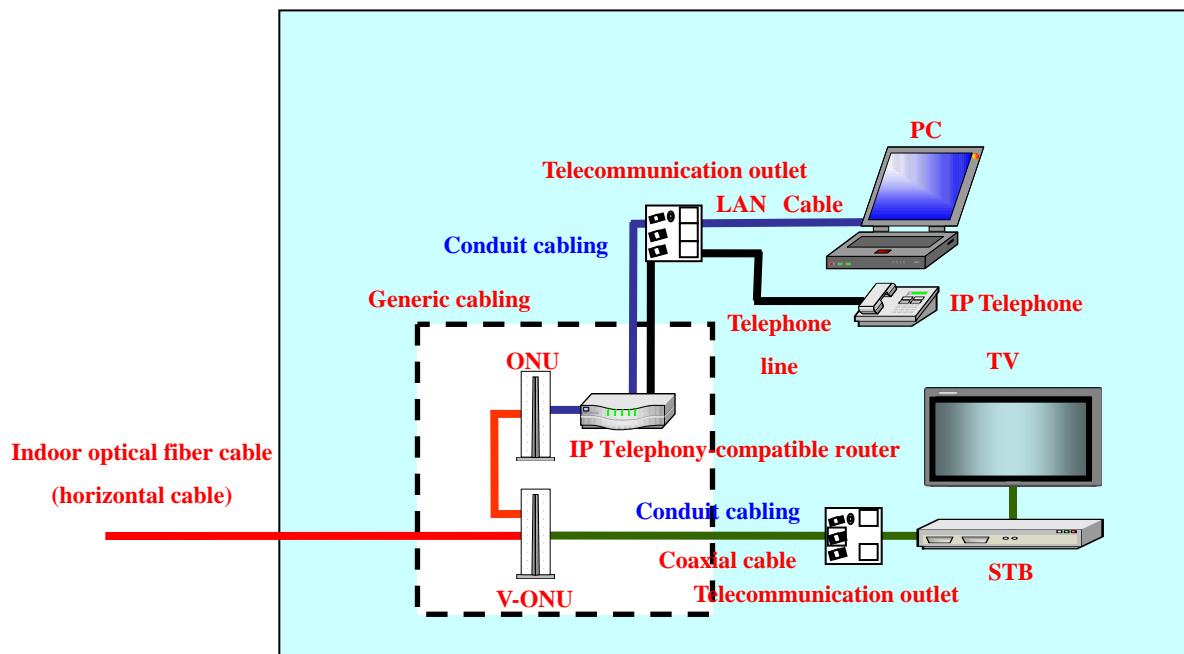

(a) Generic cabling box available (mainly for newly constructed apartment houses)

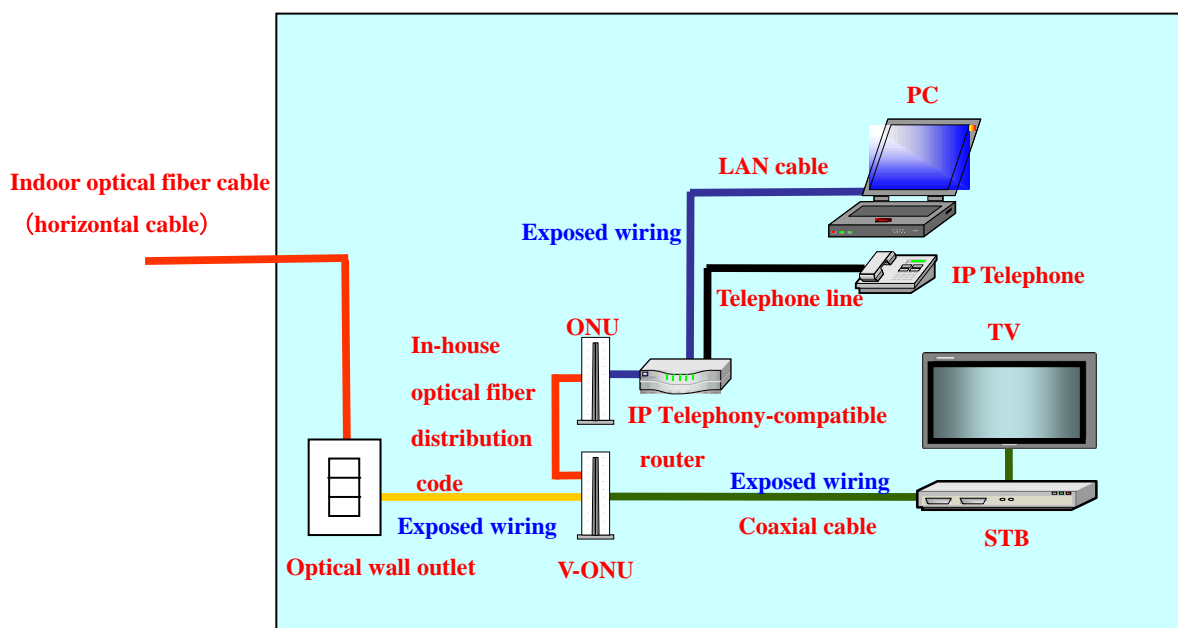

(b) No generic cabling box (mainly for existing apartment houses)

Figure 7: Example of Basic Configuration of In-House Generic Cabling

The following facility conditions are desirable.

- 1) There are conduits for cabling for optical fiber cables from the common space to the generic cabling box. The diameter of conduit is 22 mm or 16 mm.
- 2) The generic cabling box has a room for installing ONU and V-ONU, or there is a sufficient space to install the generic cabling box that can have ONU.
- 3) There is a star-shaped conduit for generic cabling from the generic cabling box to each dwelling unit. The diameter of conduit is 22 mm or 16 mm. This conduit is also used for the broadcasting purpose.

*A flexible cabling change is possible in the future if a star-shaped conduit exists to each dwelling unit from the generic cabling box on which LAN cables of optical cabling and metal cabling and coaxial cables for broadcasting purpose are concentrated.

If there is no conduit, one option is to install a LAN cable within a wall to all the rooms that currently and will need the service, and to switch the service in the generic cabling box.

It is important to consider that an in-house telecommunication infrastructure should be established to allow a flexible choice of telecommunication systems by residents.

1) Dedicated-type service (Distribution method of optical fiber direct connection)

If residents choose the dedicated-type service, a contract shall be executed directly with a service provider. In such case, the system shall be as described in Figure 8.

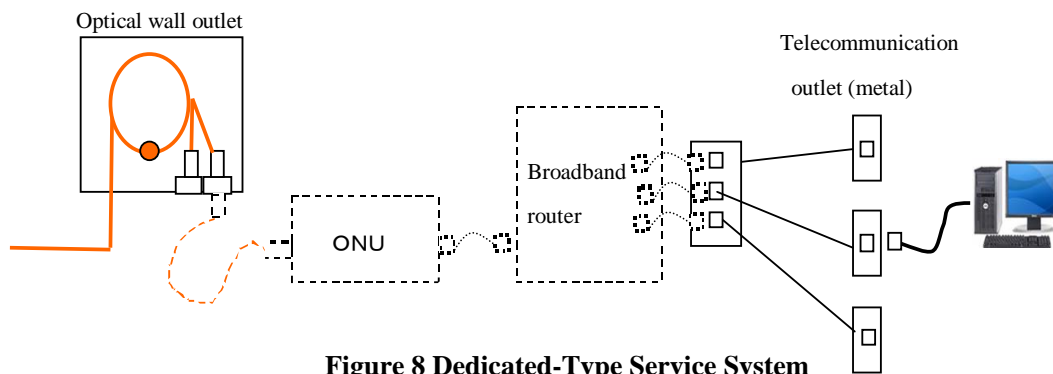

Figure 8 Dedicated-Type Service System

2) Shared-type service (optical LAN)

If residents choose the shared-type service, the system shall be as described in Figure 9. In such case, a party who installs a media converter depends on the type of contract.

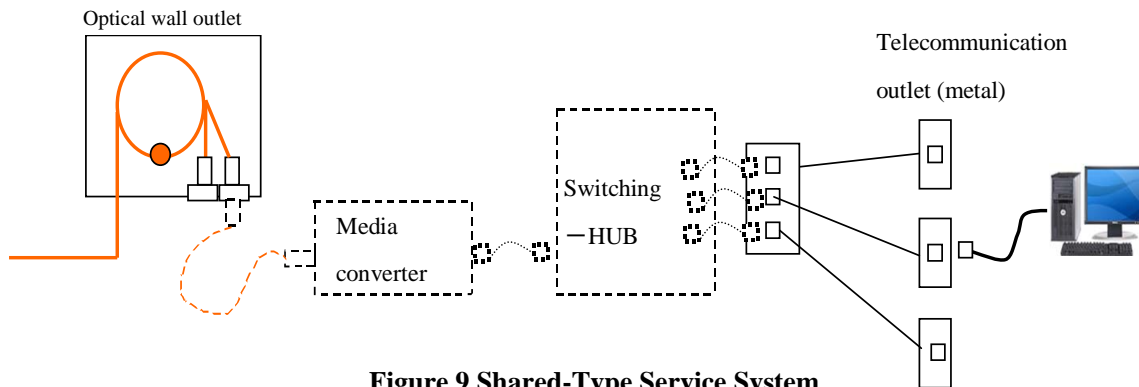

Figure 9 Shared-Type Service System

5. Cabling and connection

It shall be in accordance with TS C 0017.

6. Maintenance and management

A test result, a cabling map, and a connection management table shall be prepared in accordance with “9. Display and Management” in TS C 0017.

7. Test and performance standards

A test is conducted for transmission loss and return loss pursuant to “8. Test” of TS C 0017. It is necessary that the test result fulfills the performance standards. The testing methods and the performance standards depend on the telecommunication service provider.

The following is an example of performance standards as a reference. The calculation examples are based on the optical cabling shown in Figure 10.

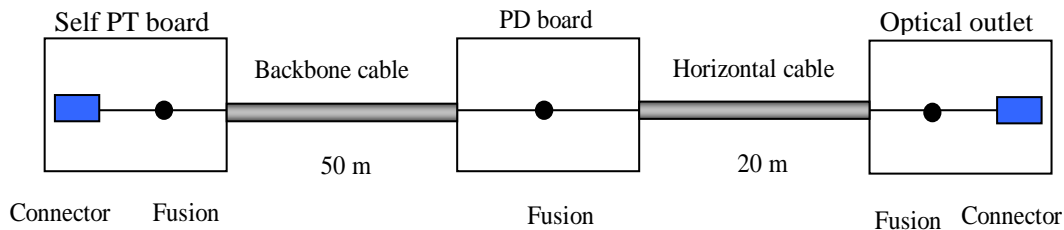

Figure 10: Optical Cabling in the Calculation Example

- Optical fiber cable : single-mode optical fiber with standard loss of 0.4dB/km
- Cabling distance: 70m
- Measuring wave length: 1.31 μ m
- Fusion splicing loss: 0.2dB or smaller
- Optical wall outlet connection loss: 0.7dB or smaller
- The number of fusion splicing: 3

Loss of Optical fiber only = Cabling distance x Cable standard loss = 0.07(km) x 0.4(dB/km) = 0.03(dB)

Optical fiber splicing loss = Fusion splicing loss x the number of fusion splicing = 0.2(dB) x 3 (points) = 0.6(dB)

Optical connection loss = 0.7(dB)

Performance standard = Loss of optical fiber only + Optical fiber splicing loss + Optical connection loss
= 0.03(dB) + 0.6(dB) + 0.7(dB) = 1.33(dB)

Reference

(1) Standardization of FTTH for Apartment Houses, B2E, October 2005

Annex A

Latest Examples of Services Using Optical Fiber distribution system

1) Current services

In the information and telecommunication facilities in an apartment house, there are many cases to use FTTH system that an optical fiber cable is installed to each dwelling unit that is used for a telecommunication facility for the Internet, a facility for telephone, common antenna TV, and an intercom facility. The following is an example of the use of optical fiber cables and the details of services.

(1) Internet

A provider usually provides an IP Telephony service and a video-on-demand service in addition to the Internet connection service. When looking from a dweller's side, if he/she chooses a dedicated-type service using an optical fiber cable, he/she can choose any service he/she wants under the high speed telecommunication environment.

(2) Telephone

A telephone facility in this paper means a telephone distribution facility for general fixed telephone service that requires an agreement with a subscribed telephone network. Recently, although a mobile phone and an IP phone are widely used, it is still necessary to install an outlet for a subscribed telephone network when constructing a new apartment house. There are some cases that a dweller connects to the Internet and uses an IP Telephony service such as "Hikari Denwa" provided by NTT including this fixed telephone cabling. Depending on the development of telephone facilities, there are possibilities that a user selects to continue using a fixed telephone with a metal cabling, or use a fixed telephone in conjunction with an IP telephone, or shift to an IP telephone.

(3) Community antenna TV

As the distance loss is large in a RF signal of metal cabling, using an optical fiber cable is very effective. Additionally, it needs a smaller space if an optical fiber with several fibers is integrated with an optical fiber for the Internet service. An example of systems includes a TV community antenna facility using an optical backbone cable to have a broadcasting service with a receiving antenna, an optical cabling system to receive a cable TV service, and a video distribution service using an optical fiber from a video distributor. In any case, as it is necessary to distribute the service to each dwelling unit in which a V-ONU (Video Optical Network Unit) should be installed, it is difficult that the cost would be reduced easily. When we look at the service side, as the full service of receiving antenna consist of the terrestrial digital broadcasting, broadcasting using a broadcasting satellite (BS) and a 110 degree east communications satellite (CS), and CS digital broadcasting service with a 2-line of twin-axial cable distribution system. On the other hand, receiving a cable TV service and the distribution by video distributor is usually handled with a one-line of single axial system. There are many CATV providers that offer an Internet connection service. In such case, it is necessary to check whether the cable for distribution is an optical fiber cable or a metal coaxial cable when considering a system within a building.

(4) Intercom

In the relationship between the apartment house entrance device and a slave unit in a dwelling unit, a space can be saved by using an optical fiber cable with several fibers and integrating with an optical fiber cable for the Internet. However, as a recent slave unit has a security function or a function to control a general entrance automatic door, or an automatic fire alarm function, it is sometimes difficult to change to optical fiber cables.

(5) Mobile Telephony service

In the upper floor of extremely high-story apartment houses, it is sometimes difficult to receive a mobile telephony wave. To solve this problem, measures for blind area are taken within the premise. A backbone cable used for the measures for blind area is usually a cable (cable) and an optical fiber cable is sometimes used.

2) Example of recent services using an optical fiber cable

The following shows an example of recent services using optical fiber cable s:

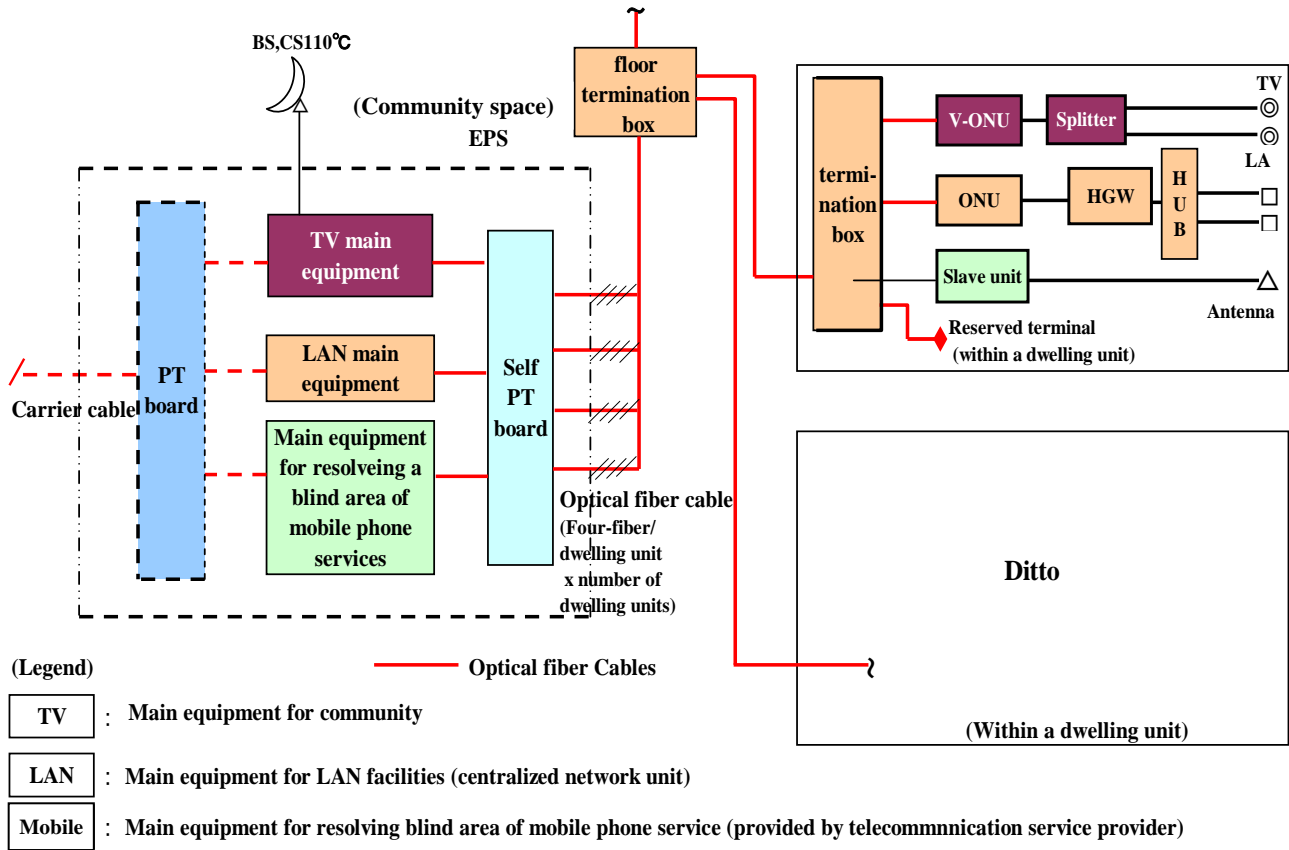

Annex A, Figure 1: FTTH Distribution Map for a certain Project

(Shared-type Internet + Common antenna TV+ measures for blind area of Mobile Telephony service)

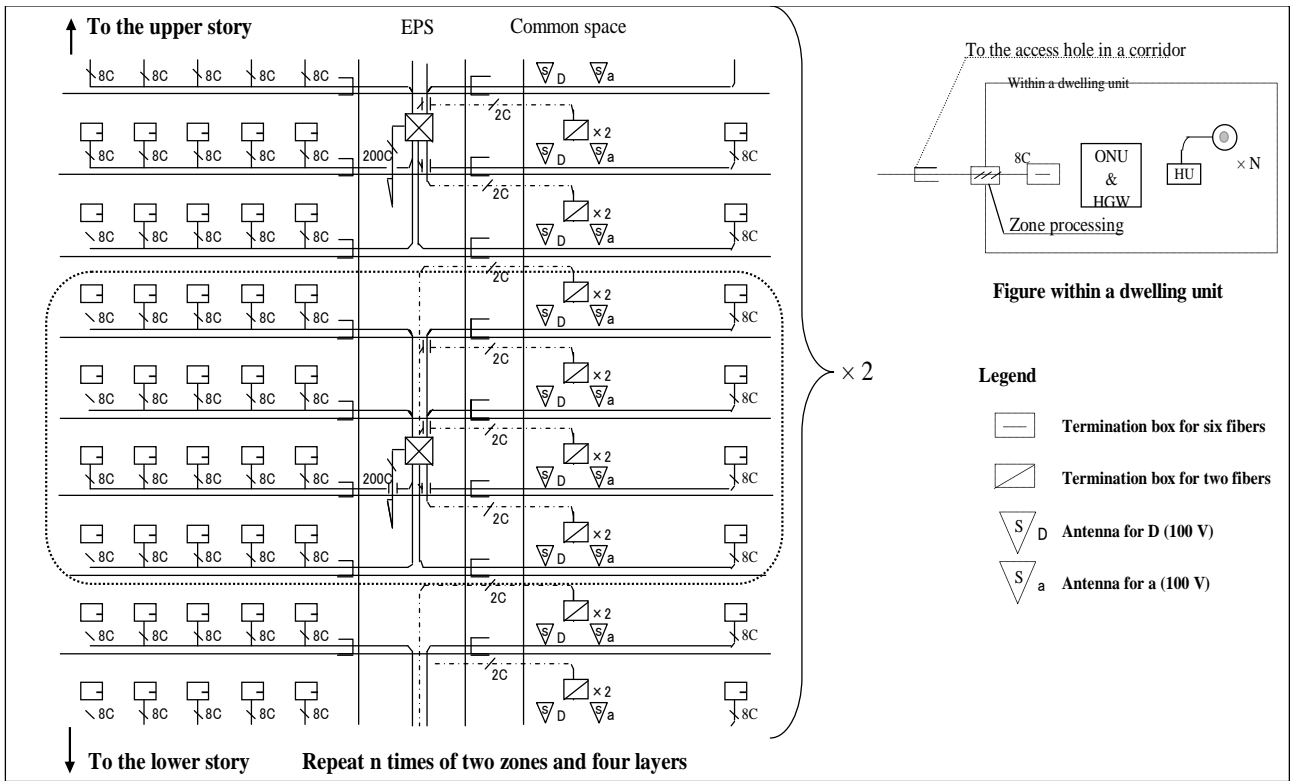

Annex A, Figure 2: FTTH Distribution Map for a certain Project

(Shared-type Internet + Dedicated Internet service + Common antenna TV + measures for blind area for Mobile Telephony service)

Annex B

Result of questionnaires about the in-house optical fiber distribution system

1. Introduction

Sub-committee on in-house optical fiber distribution system under the Fiber Optics Standardization Committee of Optoelectronic Industry and Technology Development Association (JAPAN) (OITDA) conducted a questionnaire survey on the current situation and issues about the optical fiber distribution system in a building and future challenges in November 2007 ⁽¹⁾. As we believe that the survey result is useful for the discussion about the optical fiber distribution system for apartment houses and detached houses, it is attached as Annex. OITDA also conducted a similar survey in November 1995 ⁽²⁾ and November 2002 ⁽³⁾. For the purpose of comparing the results with the past survey results, the questionnaires are basically the same as those in 2002 and only added a question to distinguish that the subject house is a newly built one or an already-built one. The major results of the current survey are as follows:

2. Survey results

(1) People subject to the questionnaire survey and the number of respondents

People subject to the questionnaire are member companies of each committee and support member companies of OITDA, and professionals in the construction and execution industries who are deeply involved in the optical fiber distribution system for customer premises. The number of questionnaire sent is 209 and the number of respondents is 77 that mean that the response rate is 37%. In the previous survey, the number of respondents was 59 and the response rate was 42%. Annex B, Table 1 shows a status and position of each respondent.

(2) Application of optical cabling to buildings and residential houses

The result is shown in Annex B, Table 2 and 3.

For the buildings optical fiber distribution system, we can confirm that FTTH is adopted as widely as LAN.

It is also found that a drop/indoor optical fiber cable and SM 0.25 mm optical fiber are very popular. Particularly, we can confirm that SM optical fiber with a bending radius of 15 mm which is recently developed and introduced in response to the needs for higher bending strength of optical fibers is being introduced.

For residential house optical fiber distribution system, as FTTH is mainly adopted and, as in the case of buildings, drop/indoor optical fiber cable using a general SM optical fiber and a SM optical fiber with bending strength of 15 mm are widely used.

Regarding the optical fiber connection, we found that SC connectors are widely used within residential house, and that a SC connector of field assemble type increases both for residential houses and buildings.

(3) Current situation and issues about optical fiber distribution system

Annex B, Table 2 shows the current condition and issues about optical fiber distribution system for building.

We believe that the optical fiber distribution system will increase step by step for buildings. With the comparison with metal cabling system, the optical fiber distribution system for buildings has a better transmission capability such as wider bandwidth and longer distance. On the other hand, the problems include smaller bending strength that would result in a wider space for installation, and longer time for connection.

Regarding the optical fiber distribution for residential houses, we expect that the optical fiber distribution system will also increase as for buildings. Problems include a longer time to handle exposed cabling due to a restriction from an exterior beauty and a permissible radius of curvature.

The common issues on the optical fiber distribution system for buildings and residential houses are the connection of optical fiber (no specific skill is required) and material and parts costs. The reduction of latter is more expected compared with the previous survey (please refer to Annex B, Table 1).

Reference

- (1) “Research and Study on Standardization of Fiber Optics” by Optoelectronic Industry and Technology Development Association (JAPAN) in March 2008.
- (2) “Report of Research and Study on Standardization of High Performance Optical Devices”, Optoelectronic Industry and Technology Development Association (JAPAN), pp.61-86, March 1996.
- (3) “Research and Study on Standardization of Fiber Optics” by Optoelectronic Industry and Technology Development Association (JAPAN) in March 2003.

Annex B, Table 1: Type of Respondents of the Questionnaires (unit: person, (%))

Type of Respondents	November 2007	November 2002	November 1995
System vendor	9(11.3)	11(16.7)	13(18.3)
Cable vendor	15(18.8)	10(15.2)	14(19.7)
Cabinet vendor	1(1.3)	1(1.5)	2(2.8)
Parts vendor	17(21.3)	9(15.2)	8(11.2)
Constructor	6(7.5)	6(9.0)	5(7.0)
Executors	9(11.3)	11(15.2)	9(12.7)
User	13(16.3)	13(19.7)	16(22.5)
Others	10(12.5)	5 (7.5)	4(5.6)
Total	80 (multiple response)	66 (multiple response)	63

Including duplicated answers.

Annex B, Table 2: Current Situation of Optical Fiber Distribution System in a Building

Figures within () means a response rate (%)

No	Item	November 2007	November 2002	November 1995
1	Number of persons who have an experience of designing and execution	27 persons	32 persons	35 persons
2	Number of designing and execution cases experienced	Existing (22), Newly constructed (19), Both (55)	(No question)	(No question)
3	Purpose of optical fiber adoption (multiple response)	LAN (56), FTTH (52), Video transmission (26), Unknown/Others (11)	LAN (88), Video transmission (34), FTTH (31)	LAN (80), Video transmission (46), Others (23)
4	Adopting place	Both the backbone riser and floor (78), Backbone only (15),	Both the backbone riser and floor (72), Backbone only (19),	Both the backbone riser and floor (60), Backbone only (37),

		Floor only (33)	Floor only (9)	Others (9)
5	Cabling space (multiple response)	Enough space for optical fiber cables (70), Enough space for a distributor (41), Space for optical fiber cables added (30), Space for a distributor added (26), Cancellation of execution/Others (7)	Enough space for optical fiber cables (69), Space for optical fiber cables added (38), Enough space for a distributor (50), Space for a distributor added (47)	(No question)
6	Type of optical fiber (multiple response)	SM optical fiber (89), 50/125 GI optical fiber (37), SM optical fiber with bend radius of 15 mm (33), 62.5/125 GI optical fiber (19), Plastic optical fiber (4), Others (4)	SM optical fiber (69), 50/125 GI optical fiber (66), 62.5/125 GI optical fiber (44), Plastic optical fiber (13)	50/125 GI optical fiber (66), SM optical fiber (40), 62.5/125 GI optical fiber (29), Plastic optical fiber (11)
7	Type of jacketed optical fiber (multiple response)	Fiber 0.25 mm jacketed optical fiber (52), optical fiber ribbon fiber (41), Fiber cable of 0.9 mm (33), Unknown (11)	Fiber cable of 0.9 mm (59), Tape fiber cable (53), Fiber cable of 0.25 mm (41)	(No question)
8	Number of optical fibers (multiple response)	To 12 optical fibers (70), 2 fibers (41), To 24 fibers (37), More than 24 fibers <36 – 200 fibers> (33), one fiber (11)	To 12 fibers (56), To 24 fibers (53), 2 fibers (44), More than 24 fibers <36 – 200 fibers> (41)	Less than 10 fibers (71), 10 – 29 fibers (20), 30 – 100 fibers (17), More than 100 fibers (3)
9	Type of optical fiber cable (multiple response)	Slot type (44), Drop/in-door cable (37), Optical cord (single fiber type or eye-glasses type) (26), Concentrated fiber type (22), Concentrated code type (19), Others (22)	Slot type (50), Concentrated fiber type (44), Code <eye-glasses type> (44), Code <single fiber> (41), Concentrated code type (41)	(No question)
10	Optical fiber connection (multiple response)	Optical connector (96) (Consisting of: Type SC (70), Field assembling SC (44), FC (22), LC (15), MTRJ (4), Others	Connector connection (84) (Consisting of: SC (78), FC (38), MTRJ (22), MU (9), LC (6))	Fusion (77), Connector connection (63) (Consisting of: FC (34), SC (20), Others

		(7)) , Fusion splicing (81), Mechanical splicing (33), POF connector (4)	Fusion (81), Mechanical splicing (28), Plastic fiber connector (9)	(9)) Mechanical splicing (9)
11	Number of persons experienced a metal cable	17 persons	30 persons	22 persons
12	Adoption of optical fiber cable to a backbone	Using optical fiber cable (88) (5- 40% (53), 50% or more (35)) No use of optical fiber cable (12)	Using optical fiber cable (67) (About 5% (33), 50% or more (20)) No use of optical fiber cable (33)	Using optical fiber cable of 5%or more (77) (20 - 30% (32), 40 - 50%(18)), 0 – less than 5% (23)
13	Adoption of optical fiber cable to floors	Using optical fiber cable (65) (50% or more (29), 10% (15), 30% (12))	Using optical fiber cable (60) (5% (13), 50%or more (13), 30% (10))	Using optical fiber cable of 5%or more (41) (5 - 10% (23), 20 - 30% (14))
14	Advantages of optical system (multiple response)	A cable is small and light/long installation is possible (76) Transmission of wider bandwidth and longer distance is allowed (71) No electromagnetic induction problem (65) No separation from a strong electric cable required (29) One cable can provide several services (29)	Transmission of wider bandwidth and longer distance is allowed (90) No electromagnetic induction problem (80) No separation from a strong electric cable is required (50)	No electromagnetic induction problem (59) No separation from a strong electric cable is required (35) A cable is light and easy to be installed (32)
15	Problems of optical system (multiple response)	Permissible radius of curvature is small that requires more space (37), Need longer time for the preparation of connection and termination (fusion) (30), Higher cost of materials (22),	Permissible radius of curvature is small that requires more space (53), High execution skill is required for optical connection (53), Higher cost of materials and parts (cables, parts) (50)	Need a more space due to non-bendable character (51) Need a longer time to connect fibers (25) No designing guidance is available (13)

		High execution skill is required for optical connection (19)		
--	--	--	--	--

Note) Item No.12 – 15 is a response from persons who experienced the execution of both optical and metal fibers. Answers in Item No.14 and 15 of 1995 include those provided by people who have not experienced a metal fiber.

Supplementary issues for Annex B, Table 2

- 1) Item No.2 – 10 are questions for people who have been involved in designing and executing optical fiber cable systems.
- 2) Item No.12 and 13 are questions for people who have experienced designing and execution of both optical and metal cable systems.
- 3) Item No.14 and 15 are questions for all the respondents.
- 4) Terminology
 - (i) Concentrated fiber type cable: Layer twist type cable with single fiber
 - (ii) MU Connector: Small connector with a ferrule radius of 1.25 mm

Annex B, Table 3: Current Situation of In-house Optical Fiber Distribution System

Figures in () means the response rate (%)

	Item	November 2007	November 2002
1	Number of persons who has a experience of optical system designing and execution	18 persons	18 persons
2	Number of designing and execution cases experienced	Existing (39), Newly constructed (28), Both (33)	(No question)
3	Purpose of optical fiber adoption (multiple response)	FTTH (89), Video transmission (22), LAN (17), Unknown (6)	FTTH (72), LAN (33), Video transmission (22)
4	Type of optical fiber (multiple response)	SM optical fiber (72), SM optical fiber with bend radius of 15 mm (50), Plastic optical fiber (17), 50/125 GI optical fiber (6), Others (11)	SM optical fiber (72), 50/125 GI optical fiber (22), Plastic optical fiber (22), 62.5/125 GI optical fiber (6)
5	Type of optical fiber cable (multiple response)	Drop cable (72), In-door cable (61), Code (single fiber or eye-glasses type) (33), Termination cable (11)	Code (single fiber) (55), Code (eye-glasses type) (39), Drop cable (28), In-door cable (28)
6	Optical fiber connection (multiple response)	Optical connector (83) (Consisting of: Type SC (72), On-site assembling type SC (44), Others (11)), Fusion splicing (44), Mechanical splicing (33), POF connector (17), Unknown (6)	Connector connection (78) (Consisting of: SC (61), MTRJ (17), MU (11)), Fusion (72), Mechanical splicing (22), Plastic fiber connector (6)

Supplementary issues about Annex B, Table 3

- 1) Item No.2 – 6 are questions for people who have been involved in designing and execution of optical fiber cable systems.

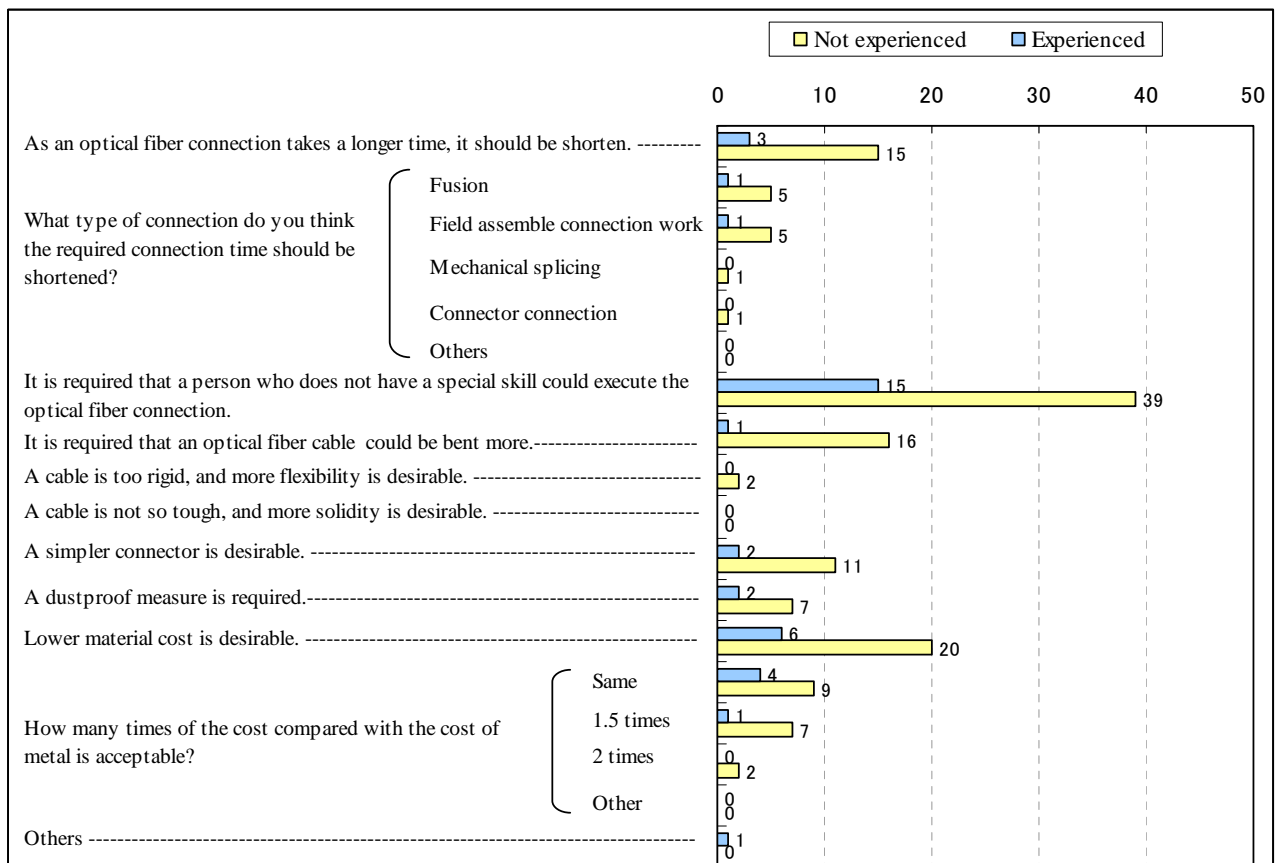

Annex B, Figure 1: Future Challenges for Optical Fiber System for Buildings and Residential Houses
 (Total number of respondents: 140 (including multiple responses))



Supplementary issues about Annex B, Figure 1

It indicates the answers of “Yes” divided by “Experienced” and “Not Experienced” in the construction and execution.

The figures are the number of respondents (upper line is “Experienced” persons and the lower line is “Not-Experienced” persons).

Annex C Table 4: Structure Examples of Cables for Optical Fiber Distribution System for Apartment Houses

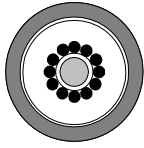
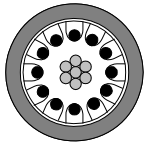
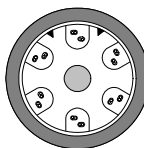
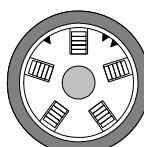
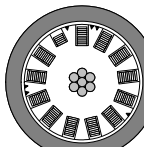
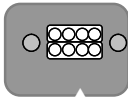
Structure examples of cables for optical fiber distribution system for apartment houses

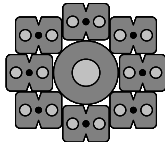
Structure	Application	Type of jacketed optical fiber	Number of Fiber	Cross Section
Single-fiber layer twist type cable	Introduction area Backbone area	0.9 mm jacketed optical fiber	up to 12 fibers	
Single-fiber slot type cable	Introduction area Backbone area	0.9 mm jacketed optical fiber	up to 12 fibers	
2-fiber ribbon SZ slot type cable	Introduction area Backbone area	2-fiber ribbon	up to 128 fibers	
4-fiber ribbon SZ slot type cable	Introduction area Backbone area	4-fiber ribbon	up to 300 fibers	
8-fiber ribbon SZ slot type cable	Introduction area Backbone area	8-fiber ribbon	up to 1000 fibers	
Multi-fiber optical indoor cable	Introduction area Backbone area	8-fiber ribbon	Four or eight fibers	
Optical indoor cable of small diameter with low friction	Backbone area Horizontal area	0.25 mm jacketed optical fiber	One fiber	
Bound flat cable	Backbone area Horizontal area	0.25 mm jacketed optical fiber	Four or eight fibers	

Description of Optical Fiber Distribution System for Apartment Houses in FTTH

This description is to explain matters that are described in the body text and Annex and other relevant matters, and not a part of the technical paper (TP).

I. History

Sub-committee on In-house optical fiber distribution system under Fiber Optics Standardization Committee of Optoelectronic Industry and Technology Development Association (currently Technical-committee on In-house optical fiber distribution system) had prepared the standard information on optical fiber distribution for customer premise, “Optical fiber distribution system for customer premises” (TS C 0017, in 1999) and standardized the optical fiber distribution system configuration, cabling method, connecting method, and testing/management method. The updated version was issued in January 2002.

(“Optical fiber distribution system for customer premises” was also updated as standard specifications to include the latest information and republished as TS C 0017 in January 2006).

More high-story apartment houses have introduced optical fiber cables along with the development of FTTH. However, as apartment houses have a special characteristic that individual dwelling unit within a premise is a subscriber of optical service, which is significantly different from the one for commercial buildings. Under such circumstances, the sub-committee started the study on apartment house structure, examination of silicon glass/plastic optical fiber and peripheral technology, collection of execution example of optical cabling, and identification of problems in 2003

In 2004 for the purpose of preparing the guideline for promoting the optical fiber distribution to apartment houses, the sub-committee examined the current condition and the latest technical trend, and also discussed about what the guideline should be. The study result of current condition showed that although an optical fiber is introduced to the entrance of the apartment building (i.e. MDF room) and the metal LAN cable is usually used within a building. For high-story apartment houses, there are increasing cases that an optical fiber is introduced for a backbone cable.

We started the preparation of Technical Paper entitled “Optical Fiber Distribution System for Apartment Houses in FTTH” in 2005 and published the first version in July 2007.

In the second version of which revision started in 2008 we added the configuration examples of in-house generic cabling with video transmission as well as the description of concrete examples of testing/performance standards. It was published in July 2009.

In 2009 the number of FTTH subscribers reached 15 million households and has increased steadily. Under such circumstances, we changed points for technical trend research on FTTH and optical fiber distribution system in premise, and conducted (v) The market and industry trend survey, in addition to collecting information by each technology area such as (i) Optical fiber cable technology, (ii) Connection technology, (iii) Execution technology, and (iv) Optical network systems. As a result, we found that more and more apartment houses have introduced an optical fiber to each dwelling unit and that more new applicable optical fiber cables, connection connectors, and other cabling materials are available that have new technology. To reflect the information, the sub-committee started the preparation of version 3 in 2010

In the version 3, the description on optical fiber cables used for apartment houses is added and Annex C “Structure Examples of Cables for Optical fiber distribution System for Apartment Houses” is attached.

II. Description of Major Items

1. Scope

The scope of this technical paper is from the introduction of optical fiber cable to an apartment house to an optical wall outlet of each dwelling unit, and excludes the in-house cabling. As in-house cabling is the same as those described in “Optical Fiber Distribution System for Detached Houses in FTTH”, please refer to that TP. The Center for Better Living also excludes the in-house cabling ⁽¹⁾.

2. Definitions and Abbreviations

The terminologies of distributor, optical fiber cable, and equipment which are major component of optical fiber distribution system are defined.

Regarding the name of distributor within a building, a distributor in which cables from outside of the building are terminated is called as a Campus Distributor (CD) or a Building Distributor (BD), and a distributor that is installed in each floor is called as Floor Distributor (FD) in TS C 0017. On the other hand, in the light electrical cabling design for apartment houses, a distributor in which incoming cables are terminated is called as a PT board, and a distributor placed in EPS is called as a PD board. In this technical paper, we adopt the words of PT board (termination board) and PD board (premise distributor).

We carefully determine the details of definitions to be consistent with those established by the Center for Better Living.

3. Referenced Standards

The TP indicates the standard described in JIS X 5150 “Campus generic cabling system”, TS C 0017 “Optical fiber distribution system for customer premises”, and other standards for optical fiber connection.

4. Basic Configuration of Optical Fiber Distribution System

The standard is a “distribution method of optical fiber direct connection” that is to connect an optical fiber cable to each dwelling unit. This method brings various benefits to residents: ensuring high speed and large capacity telecommunications to each dwelling unit and the telecommunication provider can be changed at the MDF room without entering each dwelling unit.

A more concrete basic configuration is as follows: an optical fiber connection is acceptable between a self PT board located at a MDF room and an optical wall outlet in each dwelling unit; provided that it should be one-to-one connection without a branching function. It is the same configuration as that defined by the Center for Better Living.

The distribution method of backbone cable should be determined after considering the scale and structure of apartment house (such as the number of dwelling units, location of EPS, and location of MDF), constructability, EPS space, and costs. Based on the result of current optical cabling survey, we choose the following three methods as major methods for cabling: (i) Single distribution of horizontal cable method; (ii) Single distribution of backbone cable method; and (iii) Branching distribution of backbone cable method, and describe a summary and characteristics of each method.

5. Cabling, connection, maintenance, management, testing, and performance standard

Cabling, connection, maintenance, management, and testing are conducted in accordance with TS C 0017

III. Standardization Progress in foreign countries and other domestic organizations

Regarding the standardization of distribution in premises, the international standardization process is in progress (for example, “Generic Cabling for Customer Premises”, ISO/IEC 11801, established in July 1995, 2002). However, the standardization of distribution in apartment houses has not developed yet.

In Japan, Japan Electronics and Information Technology Industries Association (JEITA) prepared the complete translation of IS 11801 in 1996, and published the updated version of “JIS X 5150: 2004”. In March 2005, Standardization Committee for Generic Cabling System published “Glossary of Generic Cabling for Customer Premises: JIS X 5150: 2004” as a JEITA standard.

Regarding the optical cabling in an apartment house, The Center for Better Living (established in 1973) made a proposal for FTTH dissemination ⁽¹⁾ and clarified issues ⁽²⁾ during the term from October 2005 to February 2006, and established the design standards for self optical cabling facilities for apartment houses ⁽³⁾ and the standards for better housing parts and materials for optical fiber distribution system equipment for apartment house ⁽⁴⁾ in December 2008. Japan Cable Television Engineering Association (JCTEA) prepared the “Guideline for Designing Optical Transmission System at Apartment Houses” in October 10 ⁽⁵⁾.

For the promotion of optical fibers in Japan, Optical Fiber Promotion Association (non profit organization authorized in May 2003) has promoted the enlightenment and dissemination of informatization and assisted the introduction optical fiber for small to medium-size building owners. In 2007, the Association conducted a verification test for adopting optical services to an existing apartment house using an elevator shaft. Advanced Info-Communications Promotion Community (NPO authorized in January 2004) has actively worked and promoted the information distribution technologies and human resource development through holding a competition of information distribution work technique and seminars and providing the technical authorization system. The Community is deeply involved in “Information network works” in the International Vocational Training Competition; Olympics in Technology, and has taken various actions in accordance with TS C 0017.

IV. Reference Materials

- (1) “Standardization for apartment houses in FTTH – Proposal about an optical fiber distribution facilities at customer premise” written by Yasuyuki Maru, by B2E (Optoelectronics Co., Ltd.), No.7, pp19-28, in October 2005
- (2) “Standardization for apartment houses in FTTH – Problems in FTTH facilities of apartment houses” written by Yasuyuki Maru, by B2E (Optoelectronics Co., Ltd.), No.9, pp34-37 in February 2006
- (3) BLP OC: 2008 “Design standard for self optical cabling facilities at an apartment house” by the Center for Better Living on December 1, 2008
- (4) BLS OC: 2008 “Good housing parts authorization standard - optical fiber distribution system equipment” by the Center for Better Living, published and effective on December 1, 2008
- (5) “Guideline for Designing Optical Transmission System at Apartment Houses” published by Japan Cable Television Engineering Association in October 2007

V. Draft Preparation Committee

The draft of this technical paper (TP) was prepared by Sub-committee on In-house optical fiber distribution system of Fiber Optics Standardization Committee at the end of 2008. The members participated in preparing the draft are as follows:

Chairman: Shin-ichi Furukawa (Yazaki Corporation) (Chairman in 2009 Member in 2011)

Chairman: Toshihiko Sekiguchi (Nippon Telegraph and Telephone Corporation) (Member in 2009 Chairman in 2011)

Member: Katsuyuki Ishibashi (Kinden Corporation)

Member: Daisuke Iwakura (Furukawa Electric Co., Ltd.)

Member: Shinji Ogawa (Sumitomo Electric Industries Ltd.) (until March 2010)

Member: Toshiaki Takahashi (Sumitomo Electric Industries Ltd.) (from April 2010)

Member: Hideo Kikuchi (Fujikura Ltd.)

Member: Akihiro Kimura (Nippon Comsys Corporation)

Member: Teruo Koyama (Mitsubishi Cable Industries Ltd.)

Member: Satoshi Takahashi (Japan Science and Technology Agency)

Member: Katsunori Tanaka (Urban Renaissance Agency) (until Jun 2010)

Member: Kazuhiko Tanaami (Urban Renaissance Agency) (from July 2010)

Member: Teruyuki Taniguchi (Sekisui Chemical Co., Ltd.)

Member: Shinichi Harada (Yokogawa Electric Corporation)

Member: Tomohiro Murakawa (Kyowa Exeo Corporation) (until June 2009)

Member: Kouji Yosida (Kyowa Exeo Corporation) (from July 2009)

Member: Hiroyuki Yoshida (Japan Standards Association) (until March 2010)

Member: Yoko Nakamura (Japan Standards Association) (from April 2010)

Observer: Atsushi Kanaegami (Industrial Science and Technology Policy and Environment Bureau, Ministry of Economy, Trade and Industry) (until March 2010)

Observer: Shigeyasu Hatsuyama ((Industrial Science and Technology Policy and Environment Bureau, Ministry of Economy, Trade and Industry) (from April 2010)

OITDA: Takeo Masuda (OITDA)

Secretariat: Takashi Inada (OITDA)

END OF DOCUMENT

All Rights Reserved

This Technical Paper (TP) for OITDA Standards was discussed, reviewed and prepared by OITDA and Sub-committee on In-house optical fiber distribution system of Fiber Optics Standardization Committee.

Please contact below for your opinions and questions.

Technical Paper (TP):

Optical fiber distribution system for apartment houses in FTTH

TP Number: TP02/BW-2011

Version 3.0

Version 1.0: Issued on July 6, 2007

Revised Version 2: Issued on June 12, 2009

Revised Version 3: Issued on August 8, 2011

Published by : Optoelectronic Industry and Technology Development
Association (JAPAN)

Address: Sumitomo Edogawabashi Station Building 7F, 1-20-10,
Sekiguchi, Bunkyo-ku, Tokyo, 112-0014, JAPAN

TEL: 81-3-5225-6431, FAX: 81-3-5225-6435

e-mail:hyojun@oitda.or.jp (Standardization Office)